



High Precision Surface Grinder



Taichung SMEs
Golden Hand
Award



National Brand
Yushan
Award



Innovative And
Customer
Satisfaction



Taiwan
Excellence
Silver Award



2018
The Rising Star
Award



ISO 9001: 2015



Machinery
Directive
Number 1674



Taiwan Enterprises
Innovation Award

EQUIPTOP HISTORY

- 1988 Established "EQUIPTOP MACHINERY CO., LTD" Made a speciality of developing high precision surface grinders.
- 1990 Developed ESG-618 & 818 ASD series, 3 axis fully automatic surface grinders. Used PC-CAD to upgrade mechanical design and development.
- 1992 Developed ESG-1228 & 1236 ASD series, 3 axis fully automatic surface grinders.
- 1993 Developed ESG-1632 & 1640 ASD series, 3 axis fully automatic surface grinders.
- 1995 Developed ESG-1020 & 1224 ASD series, 3 axis fully automatic surface grinders.
Obtained CE-Mark certificate from AMTRI CE in England.
- 1997 Developed ESG-2448 to 2480, 3axis fully automatic, digital positioning ADX series, with a downfeed jog movement providing just 0.5 μm super microfeed for finer production finish. Column type surface grinder, using high anti-wear, heavy duty preloaded, H class linear guideway.
- 1998 Awarded ISO 9002 Certification by DNV company of Netherlands.
- 1999 Invested in "NANJING EQUIPTOP PRECISION MACHINERY CO., LTD." as branch in China.
- 2000 Developed ESG-3260 to 32120, 3axis fully automatic, smart digital positioning ADX series.
Reveived certified CE-MARK by DNV company.
- 2001 Awarded Certified ISO 9000 by Bell company.
Developed NC series, 3 axis fully automatic smart digital positioning grinders.
- 2002 Grand Opening of a new factory. The new facility is over 13,000m².
Invested 1.6 hundred million dollars in this new headquarters.
Successfully developed new complex grinders, moving EQUIPTOP into the high technology area.
Renamed the company as "EQUIPTOP HITECH CORP."
- 2003 Awarded publication 2000 ISO 9001 certification. Developed "ASD II " series, 3 axis, fully automatic digital positioning grinders.
Developed "ACUMEM " super microfeed servo control and auto-wheel dressing & compensation system grinders.
- 2004 Established the branch in Wu Hsi-Shuai Hung Precision Machinery LTD. to expand China market.
Developed cantilever type ESG-6120~8300 ASD II series, 3 axis, fully automatic surface grinders.
- 2005 Obtained the prize of Taiwan Precision Product in manufacturing NC surface profile grinder.
- 2006 Developed ETM510APC tapping machine with auto pallet changer system & Double column grinding machine, table size 1500x3000~1500x5000 are available.
- 2008 Double column grinding machine, table size 1500x3000~1500x5000 are available.
- 2010 Upgrade ASD II series to TD type. PLC control & touch color screen.
- 2012 Double column type grinding machine, table size 1200x3000~1200x5000 are available.
Developed ESG-2448 to 24120, 3axis fully automatic TD type with touch color screen.
- 2013 Execute rotary & square constitute, hydrostatic spindle and guide rail program.
Presented EMV-600APC auto pallet change, and 800 x2000~5000mm, 1000x2000~5000 mm double column grinders.
- 2016 **Innovation patented invention:**
 1. Innovation surface grinding machine controller: **Patent No.:1546161**
 2. Innovation equal feeding speed control: **Patent No.:M454893**
 3. Innovation rotary & square constitute design: **Patent No.:1508818 & M454892**
 4. Innovation multi-sound alarm light structure: **Patent No.: M486838**
- 2017 Presented at TIMTOS, March 2017, 1224-TD Plus, EG-36 CNC and ERG-600CNC, with man-machine controller.
The operation and application showed In an Industrial 4.0 demonstration line.
Wining with honor: D&B TOP 1000 SMEs Elite Award
The 14th National brand: Remarkable enterprise Yushan Award.
Taichung city the 16th excellent SMEs Golden hand award.
Republic of China prominent enterprise management association, the 18th golden peak award:
Top 10 excellent business pioneer model.
Republic of China prominent enterprise management association, the 18th golden peak award:
Top 10 remarkable innovative research and development
- 2018 Developed TD PLUS, ADC, 1224CNC, 818CNC, 818CNC with CAD/CAM, 84CNC and 104CNC high precision grinding machine.
The 14th Golden torch prize of OMEA: Research and Innovation Design Award. TD PLUS (ADC) Smart High Precision surface Grinding
The 14th Golden torch prize: Top ten enterprises, Best Customer Satisfaction / TD PLUS (ADC) Smart High Precision surface Grinding
The 15th National Brand Yushan Award Best Product Category TD-Plus(ADC)
The 24th Central Regional SMEs Excellence General Manager Award
The 36th National SMEs Excellence General Manager Award
The 21st Rising Star Award of Economic Affairs Ministry
The 25th Taiwan SMEs Innovation Award TD-Plus(ADC) Series Smart Precision Grinding
- 2019 Developed hydrostatic double column grinding machine, 1200X2000~1200X5000mm series.
Taiwan Excellence Trademark
- 2020 Taiwan Excellence Award TD/ADC Smart Grinding Machine
- 2021 Taiwan Excellence Award ERG Rotary Table Grinding Machine
The 29th Taiwan Excellence Silver Award, High Precision ERG Rotary Table Grinding Machine
Taiwan Excellence Award CAD/CAM Grinding Machine
TD series smart grinding machines, with cumulative sales of more than 2,500 units.
- 2022 The 30th Taiwan Excellence Award TD NC Advance intelligent surface Grinding Machine

GRINDER FEATURE



UF / ESG-618 MANUAL TYPE.

UF / ESG-618M / 818M MANUAL TYPE(BALLWAY)

1 A : LONGITUDINAL HYDRAULIC.

2 A : LONGITUDINAL HYDRAULIC AND CROSSFEED MOTORIZED.

3 A : LONGITUDINAL HYDRAULIC, CROSSFEED MOTORIZED AND RAPID UP / DOWN MOTORIZED.

ASD II : FULLY AUTOMATIC IN 3 AXIS(X.Y.Z) WITH STEPPING MOTOR FOR DOWNFEED, AND AC MOTOR FOR RAPID UP / DOWN & DIGITAL POSITIONING.

TD : EQUIPPED PLC CONTROL AND MAN-MACHINE 7.2" TOUCH COLOR SCREEN.

TDNC : 10" TFT LCD TOUCH COLOR SCREEN

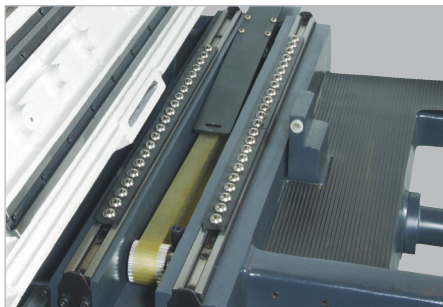

Patented steel wire timing belt transmission system (for 618M / 818M only) High precision slides way & steel balls assemble that allow lasting accuracy and smooth movement.



Indexible table handwheel (Manual type only)

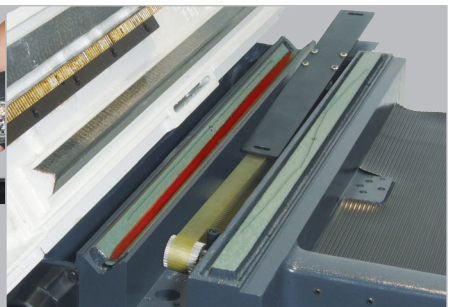

Hand scrapped one "V" one "-" Turcite-B slide ways for table longitudinal movement.

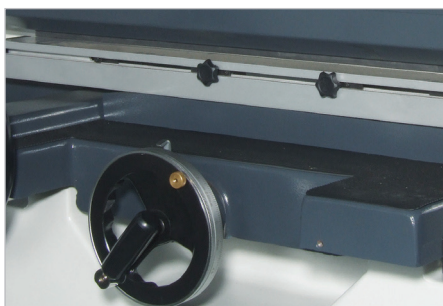
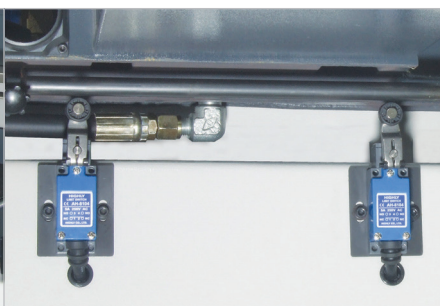

Table travel adjustment, provide built-in-type (hidden) proximity switch, features safe and easy operation (for 1A above).



2A. 3A. ASD models cross traverse system



The saddle rests on precision hand-scraped double V ways, and the table rests on precision hand-scraped V and flat ways which coated with "TURCITE-B". These guide ways are equipped with auto lubrication to resist wear of guide ways, plus lasting accuracy and damping.

MANUAL SERIES

UF / ESG-618 MANUAL TYPE

UF / ESG-618M / ESG-818M MANUAL TYPE (BALL WAY)



UF-618 / UF-618M ; UF818 / UF-818M



ESG-618 / ESG-618M ; ESG-818 / ESG-818M

HYDRAULIC SERIES



- 1 A : LONGITUDINAL HYDRAULIC.
- 2 A : LONGITUDINAL HYDRAULIC AND CROSSFEED MOTORIZED.
- 3 A : LONGITUDINAL HYDRAULIC, CROSSFEED MOTORIZED AND RAPID UP / DOWN MOTORIZED.



ESG-1A618 / ESG-1A818
ESG-2A618 / ESG-2A818
ESG-3A618 / ESG-3A818



ESG-1A1020 / ESG-2A1020 / ESG-3A1020
ESG-2A1224 / ESG-3A1224

HYDRAULIC SERIES

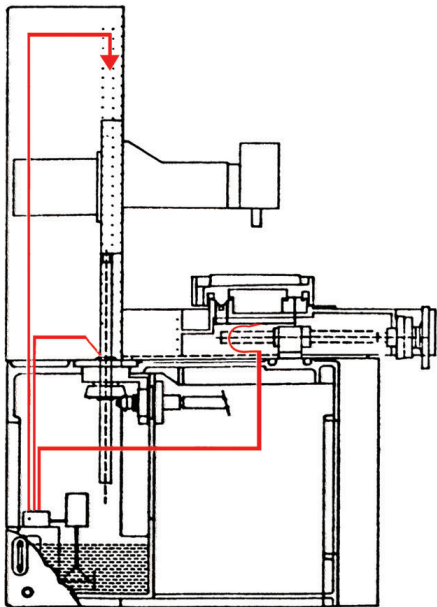

Auto lubrication system



ESG-3A1228 / ESG-3A1236
ESG-3A1632 / ESG-3A1640



1228-1648 models high precision spindle

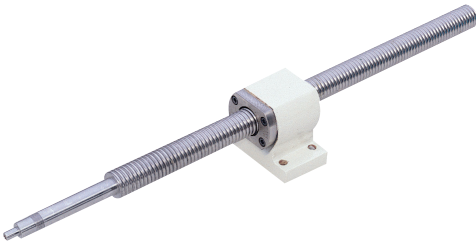

cross feed High precision ball screw



Easy-adjust guarded proximity switch (long & cross)



1228-2040 models table speed control



Enlarge double V base. These guide ways are equipped with auto lubrication to resist wear of guide ways, plus lasting accuracy & damping.

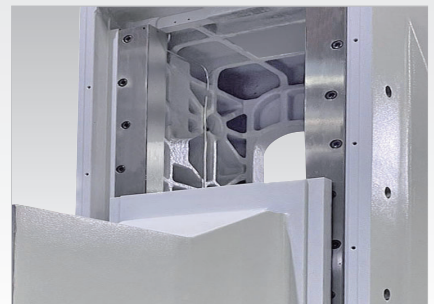

Honeycomb-ribbed column

DIGITAL SETTING

ESG-818ASD II / ESG-1020ASD II
 ESG-1224ASD II / ESG-1228ASD II / ESG-1236ASD II
 ESG-1632ASD II / ESG-1640ASD II / ESG-2040ASD II



ASD II Control Panel



- Vertical feed powered by dual motors; AC motor for rapid up / down. Stepping motor for micro downfeed positioning & slow up / down. Quick digital output feedback by encoder.
- Cross transverse travel powered by DC servo motor. Allows step feed & continuous infeed grinding. The speed for wheel dressing can be adjusted on the panel.
- Display the position of Y axis to show present spindle elevation position. The digital display is for setting start point, rough grinding volume, start point for finish grinding (finish grinding volume), downfeed volume for finish grinding, target point, rise up point, intermittent sparkout, and sparkout.

NEW **TDNC PLC SERVO**



ESG-1224 TDNC
An interface for humanistic Technology

NEW TDNC PLC SERVO

Human For High Precision



- 10" TFT LCD touch color screen
- Chuck Controller (OPT)
- Table speed control

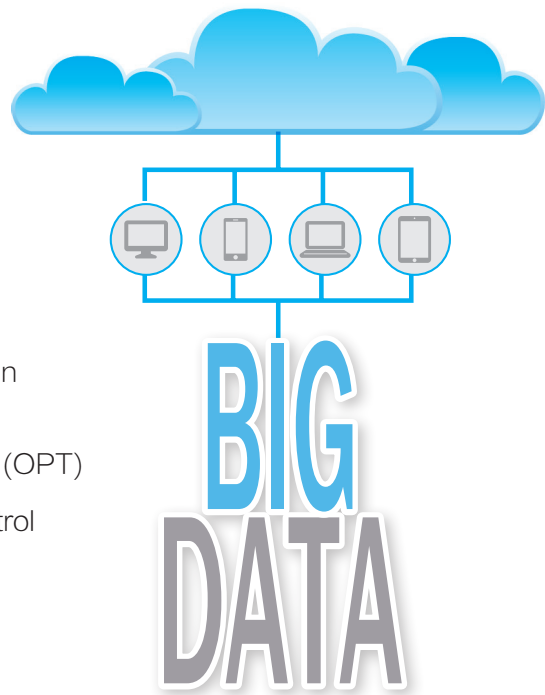

New Generation humanware

• COLUMN

Enlarged honeycomb ribbed column especially suitable for heavy duty grinding.

•

HIGH ANTI-WEAR GUIDE-WAYS

The saddle rests on precision hand scraped double V ways, and the table rests on precision hand scraped V and flat ways which coated with "TURCITE-B" These guide ways are equipped with auto lubrication to resist wear of guide ways, and provide stable movement and durable accuracy.

• CROSS FEED

Cross feed ball screw and drive by AC servo motor, there are two speed rates – rough grinding speed and finish grinding speed, provide high efficiency.

• OPERATION PANEL

DELTA man-machine 10" touch color screen equipped DELTA PLC digital control and EQUIPTOP exclusive pictures mode working system, easy to learn and operate.



Honeycomb-ribbed column

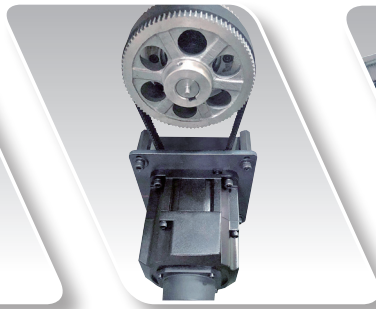

Servo Motor Driver

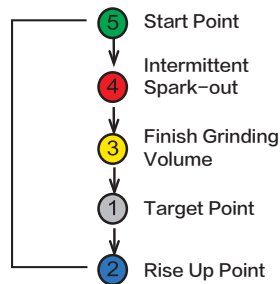
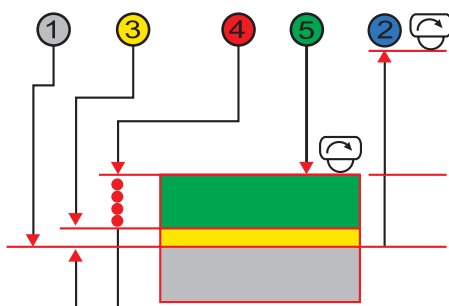
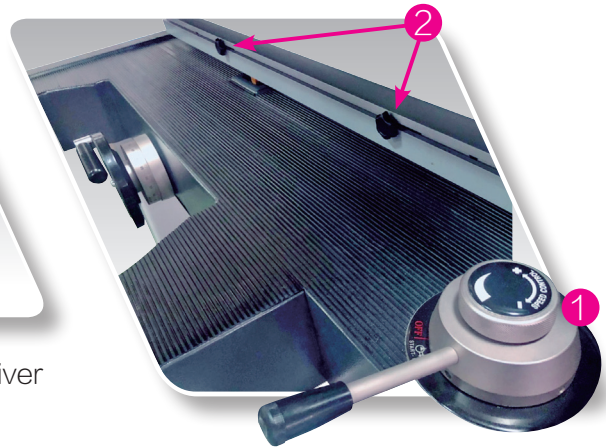

- 1 Table speed control
- 2 Easy-adjust guarded proximity switch

Enlarge double V base



These guide ways are equipped with auto lubrication to resist wear of guide ways, plus lasting accuracy & damping.

- On TDNC models, you can set the vertical zero point, start point, finish grinding volume, target point and the grinding wheel rise-up point. The machines features a simple & clear digital display & touch control panel for easy learning and efficient operation
- Vertical feed powered by an efficient AC servo motor.
- Vertical positioning is displayed on the screen showing present spindle and setting the start point, rough grinding volume, finish grinding volume, downfeed volume for finish grinding, target point, rise up point, intermittent spark-out.
- Cross transverse travel is powered by a AC servomotor. This allows step feeding & continuous infeed grinding. The speed of wheel dressing can be adjusted on the panel.

NEW TDNC PLC SERVO

Starting homepage: language selection



input/output signals: Quickly provide maintenance to determine the fault problem

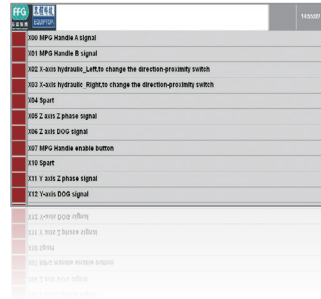

Workpiece grinding condition size setting

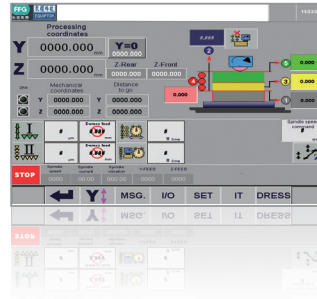

Auto wheel dressing ADC setting screen (OPT)



Manual Dynamic balance setting (OPT)

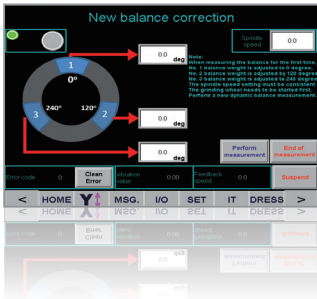

Big Data

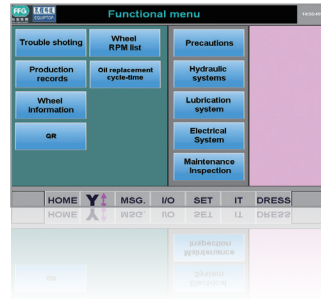

Grinding wheel speed comparison chart

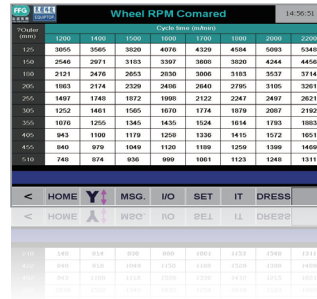

Alarm message

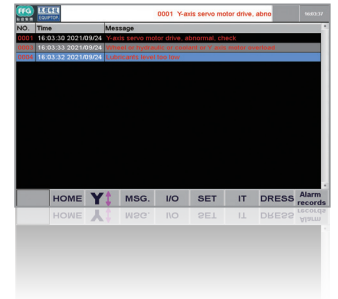

Various parameter setting

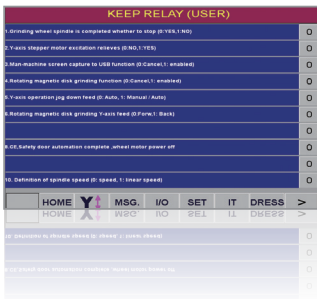

Monitoring I/O mode setting



Monitoring I/O information

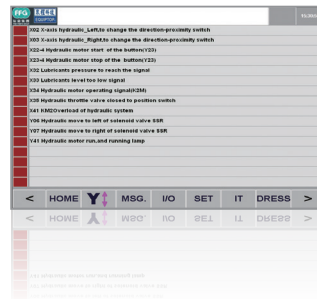

Oil change information screen

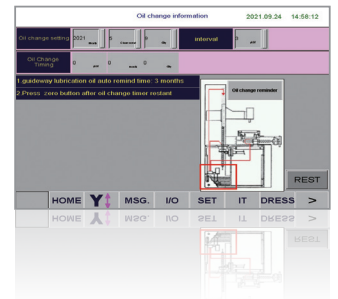



Old service mechanism

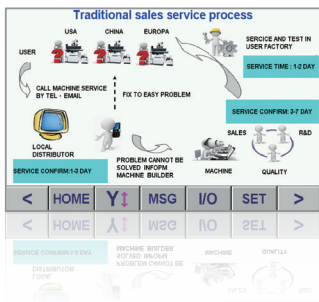

New service mechanism

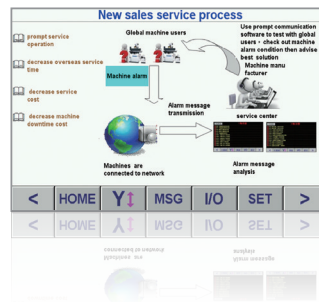

Multi-machine monitoring mode

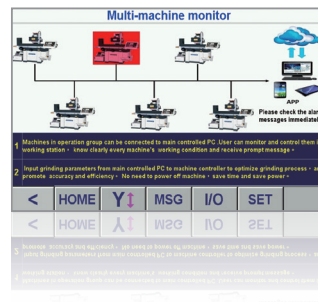

Easy Touching
Convenient
Colorful LCD

Y-axis data setting page

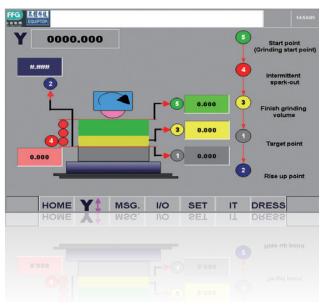

Error exclusion SERVO screen



Exception removal instruction screen

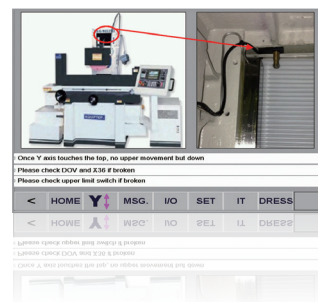

Alarm message

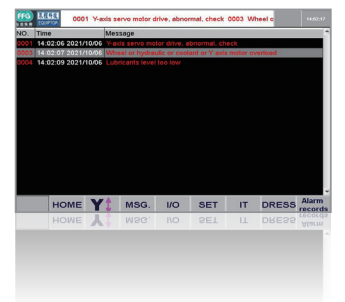

Mechanism and electrical component parameter setting screen

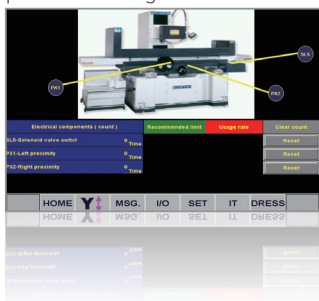

electrical components status

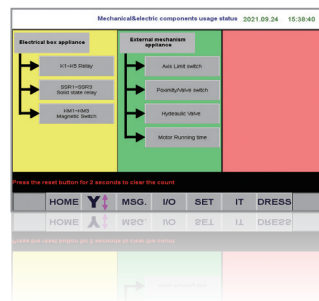

Machine running time



System parameter setting

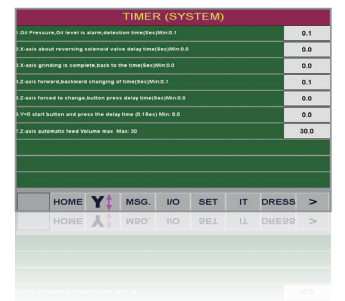

NEW TDNC PLC SERVO

ESG-1020 TDNC
ESG-1224 TDNC



ESG-818 TDNC





ESG-1632 TDNC
ESG-1640 TDNC



ESG-2040 TDNC



NEW **TDNC PLC SERVO**

Overhead auto wheel dressing and compensation mechanism (OPT)



Column Moving Surface Grinders

ESG-2448 TDNC / ESG-2460 TDNC / ESG-2480 TDNC / ESG-24120 TDNC
ESG-3260 TDNC / ESG-3280 TDNC / ESG-32120 TDNC



SPECIAL OPTIONS

Overhead auto wheel dressing and compensation mechanism

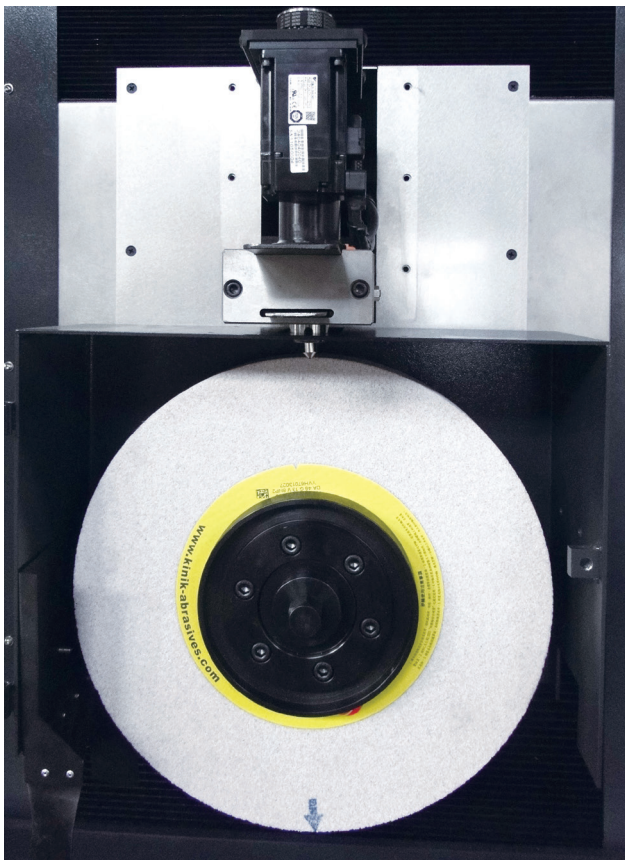

- Overhead auto dressing and compensation system, it can improve processing efficiency and save processing time.
- Auto dresser downfeed by SERVO motor, ensure the accuracy of dressing wheels.
- 1224~2040 TDNC model only.

ADC dressing

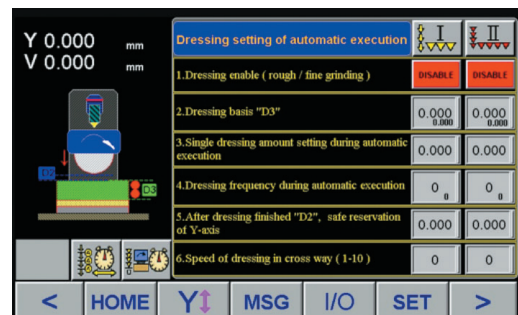

ADC dressing

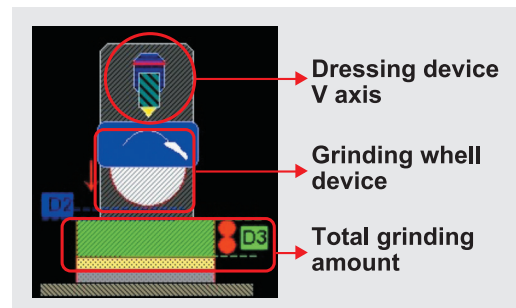

Manual dressing

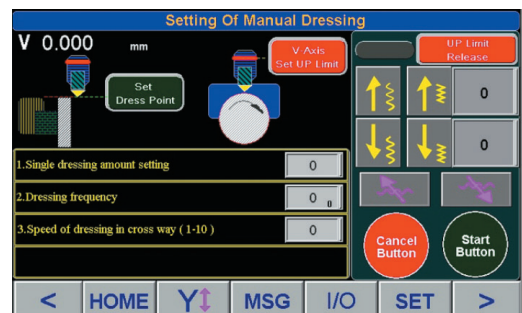

Overhead / On table type of **TDNC**



ESG-2040 TDNC

- Fully Enclose Splash Guard (OPT)
- Auto wheel dressing and compensation mechanism (OPT)



SPECIAL OPTIONS

On table auto wheel dressing and compensation mechanism

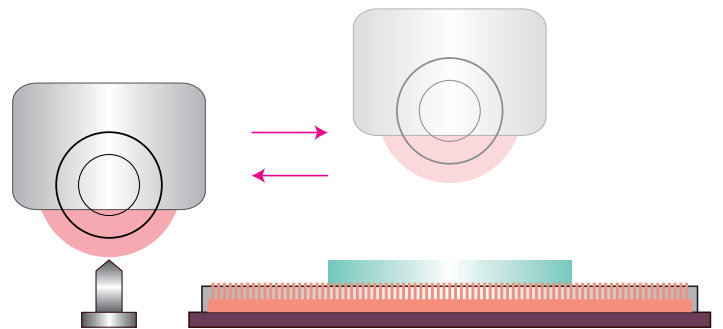

- Positioning on the left side of the work table, auto dressing and compensation.
- It can optional forming diamond wheel auto dressing and compensation mechanism.(TDNCII model)
- 1020~2040 TDNC model only.

Optional Accessories

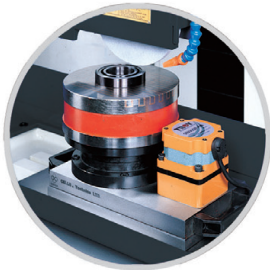

ADJUSTABLE SPEED ROTARY MAGNETIC CHUCK



PERMANENT MAGNETIC CHUCK



ELECTRO MAGNETIC CHUCK

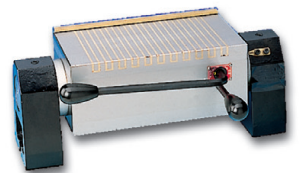

INCLINABLE PERMANENT MAGNETIC CHUCK



COOLANT SYSTEM WITH MAGNETIC SEPARATOR



COOLANT SYSTEM



COOLANT AND DUST UNIT



AUTO PAPER FEEDING DEVICE WITH MAGNETIC SEPARATOR



DUST COLLECTOR



COOLANT SYSTEM WITH MANUAL PAPER FEEDING

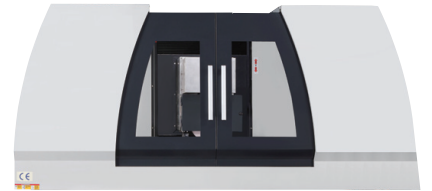

FULLY ENCLOSED SPLASH GUARD

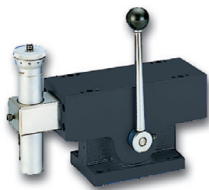

MANUAL PARALLEL DRESSING ATTACHMENT



CHUCK CONTROL WITH DEMAGNETIZER

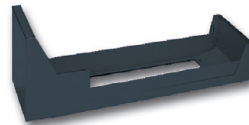
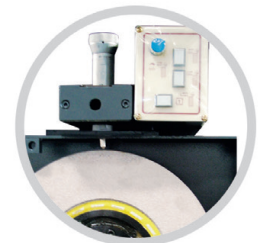
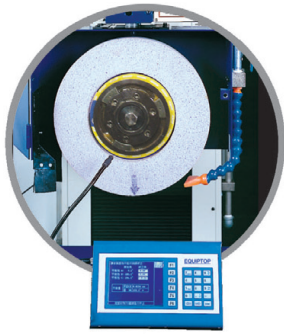

TABLE TYPE SPLASH GUARD For 618 / 818



ELECTRIC PARALLEL DRESSING ATTACHMENT



DYNAMIC BALANCER

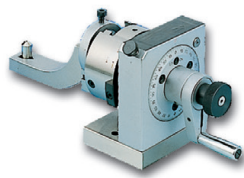

PUNCH FORMER

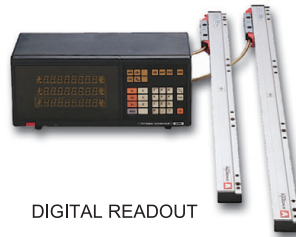

DIGITAL READOUT



MANUAL PULSE GENERATOR



SPARE WHEEL FLANGE



HALOGEN WORK LIGHT

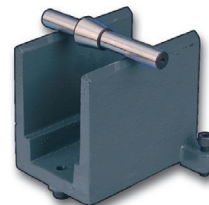

BALANCING STAND (DOUBLE LINE)



INVERTER



ROLLER TYPE BALANCING STAND



MICRO CROSSFEED FOR 618/818 SERIES

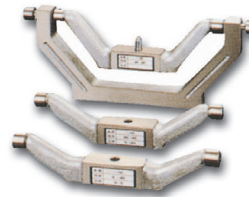

CONCAVE/CONVEX FORMING DRESSER



HYDRAULIC OIL COOLING SYSTEM



MICRO DOWN-FEED FOR 1020 SERIES ABOVE



MANUAL PULSE GENERATOR FOR ASD II ,TD TYPE

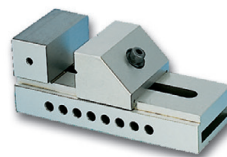

PRECISION VICE

TDNC / TDNCII Specification

MODEL		ESG-818 TDNC	ESG-1020 TDNC ESG-1020 TDNCII	ESG-1224 TDNC ESG-1224 TDNCII
DESCRIPTIONS				
TABLE SIZE	L x W	203 x 460mm	254 x 508mm	300 x 600mm
Max. grinding length	Longitudinal	480mm	520mm	600mm
Max. grinding width	Crosswise	228mm	280mm	300mm
TABLE loading	MAX. loading	202KGS	280KGS	310KGS
Max. Distance from table surface to spindle centerline		460mm	Standard column:500mm / Optional high column:600mm	580mm
standard magnetic chuck size		200 x 450mm	250 x 500mm	300 x 600mm
Longitudinal movement of table	Max. Travel, hydraulic	480mm	580mm	650mm
	Max. Travel, manual	510mm	620mm	730mm
	Max. Travel, infinitely variable	60HZ, 5-25 m/min ; 50HZ, 5-20 m/min		
Cross transverse travel	Auto transverse increment	0.1-10mm	0.1-13mm	0.1-19mm
	Auto constant feeding speed	20-320mm/min		
	Max.auto transverse travel	235mm	270mm	310mm
	Max. manual transverse travel	250mm	300mm	340mm
	Handwheel per revolution	5mm		
	Handwheel per graduation	0.02mm		
wheelhead vertical infeed	Automatic infeed	0.001 ~ 0.05mm		
	step feed(Jog)	0.001mm		
	Rapid travel, Approx	400mm/min		
	Slow travel Approx.	80mm/min		
Grinding spindle drive	Speed	60HZ, 3450 R.P.M. / 50HZ, 2850 R.P.M.		60HZ, 1750R.P.M. / 50HZ, 1450R.P.M.
	Power rating	2.0HP	3.0HP	5.0HP
standard grinding wheel	Diameter	203mm		305mm
	Width	Standard:12.7mm Optional:19mm	Standard:19mm Optional:25mm	31.75mm
	Bore	31.75mm		76.2mm
Hydraulic motor	power rating	1.0HP	2.0HP	
Crossfeed motor	power rating	400W		
Elevating motor	power rating	400W	750W	
Floor space	Total space required	2918 x 2692 x 1733 mm	3001 x 3100 x 1710 mm	3265 x 3100 x 1810 mm
Weights	Net weight, Approx.	1205 KGS	1810 KGS	1990 KGS
	Gross weight Approx.	1375 KGS	2160 KGS	2290KGS
Coolant system	power rating	1/8 HP		
Rated power, Approx	power rating	4HP	7HP	9HP
Packing dimensions	L x W x H	1880 x 1830 x 1960 mm	2450 x 2180 x 2110 mm	2450 x 2180 x 2110 mm



ESG-1228 TDNC ESG-1228 TDNCII	ESG-1236 TDNC ESG-1236 TDNCII	ESG-1632 TDNC ESG-1632 TDNCII	ESG-1640 TDNC ESG-1640 TDNCII	ESG-2040 TDNC ESG-2040 TDNCII
305 x 712mm	305 x 915mm	406 x 813mm	406x1020mm	506x1020mm
712mm	915mm	813mm	1020mm	1020mm
330mm		410mm		500mm
346KGS	379KGS	420KGS	428KGS	465KGS
Standard column: 620mm / Optional high column: 720mm				
300 x 700mm	300 x 900mm	400x800mm	400 x 1000mm	500 x 1000mm
760mm	960mm	890mm	1060mm	1060mm
830mm	1000mm	930mm	1100mm	1100mm
60HZ, 5-25 m/min ; 50HZ, 5-20 m/min				
0.1-25mm				
20-320mm/min				
350mm	430mm		510mm	
380mm	460mm		520mm	
5mm				
0.02mm				
0.001 ~ 0.05mm				
0.001mm				
400mm/min				
6mm/min				
60HZ: 1750 R.P.M. / 50HZ: 1450 R.P.M.				
Standard: 5HP ; Optional: 7.5HP				10HP
355mm				
50mm				
127mm				
3.0HP				
750W				
1KW				
3608 x 3417 x 1943 mm	4270 x 3337 x 1935 mm	3930 x 3510 x 1943 mm	4580 x 3507 x 1944 mm	4768 x 4075 x 2075 mm
3020 KGS	3330 KGS	3400 KGS	4000 KGS	4800 KGS
3520 KGS	3700 KGS	4000 KGS	4500 KGS	5200 KGS
1/8 HP				
Standard:10.5HP ; Optional:13HP				13.5HP
2670 x 2290 x 2240 mm	2930 x 2290 x 2240 mm	2930 x 2290 x 2240 mm	3120 x 2290 x 2240 mm	3500 x 2290 x 2460 mm

The manufacturer reserves the right to modify the design, specifications, mechanisms, etc., To improve the performances of the machine without notice.

ESG Specification

MODEL		UF-618 / 618M ESG-618 / 618M ESG-1A618 / 2A618	ESG-3A618 ESG-618ASD II	UF-818M ESG-818 / 818M ESG-1A818 / 2A818	ESG-3A818 ESG-818ASD II	ESG-2A1020	ESG-3A1020 ESG-1020ASD II		
DESCRIPTIONS	TABLE SIZE	L x W		152x460mm		203x460mm		254x508mm	
Max. grinding length	Longitudinal	480mm				520mm			
Max. grinding width	Crosswise	178mm		228mm		280mm			
TABLE loading	MAX. loading	160KGS		202KGS		280KGS			
Max. Distance from table surface to spindle centerline		460mm				Standard column:500mm / Optional high column:600mm			
standard magnetic chuck size		150x450mm		200x450mm		250x500mm			
Longitudinal movement of table	Max. Travel, hydraulic	480mm				580mm			
	Max. Travel, manual	510mm				620mm			
	Max. Travel, infinitely variable	60HZ, 5-28m/min ; 50HZ, 5-23m/min		60HZ, 5-25m/min ; 50HZ, 5-20m/min					
Cross transverse travel	Auto transverse increment	0.5 -10mm				0.5 -13mm			
	Auto constant feeding speed	20-320mm/min							
	Max. auto transverse travel	180mm		235mm		270mm			
	Max. manual transverse travel	195mm		250mm		300mm			
	Handwheel per revolution	5mm							
	Handwheel per graduation	0.02mm							
wheelhead vertical infeed	Automatic infeed	ASD II : 0.001-0.1mm							
	step feed(Jog)	-	0.001mm	-	0.001mm	-	0.001mm	-	0.001mm
	Rapid travel, Approx	-	270mm/min	-	270mm/min	-	270mm/min	-	270mm/min
	Slow travel Approx.	-	70mm/min	-	70mm/min	-	70mm/min	-	70mm/min
	Handwheel revolution	1mm ★ASD II : Min. display value: 0.001mm (no elevating handwheel)							
Handwheel graduation	0.005mm ★ASD II : Min. display value: 0.001mm (no elevating handwheel)								
Grinding spindle drive	Speed	60HZ, 3450R.P.M. / 50HZ, 2850R.P.M.							
	Power rating	2.0HP				3.0HP			
standard grinding wheel	Diameter	203mm							
	Width	Standard: 12.7mm ; MAX: 19mm				Standard: 19mm ; MAX: 25mm			
	Bore	31.75mm							
Hydraulic motor	power rating	1HP				2.0HP			
Crossfeed motor	power rating	40W / ASD II : 500W				80W / ASD II : 500W			
Elevating motor	power rating	-	60W	-	60W	-	80W	-	80W
Floor space	Total space required	2942 x 2401 x 1733 mm		2992 x 2468 x 1733 mm		3001 x 2815 x 1710 mm			
Weights	Net weight, Approx.	820KGS	850KGS	1170KGS	1205KGS	1780KGS	1810KGS		
	Gross weight Approx.	970KGS	1000KGS	1340KGS	1375KGS	2130KGS	2160KGS		
Coolant system	power rating	1/8 HP							
Rated power, Approx	power rating	3.0HP / ASD II : 4.0HP				5.5HP / ASD II : 6.0HP			
Packing dimensions	L x W x H	1880 x 1430 x 1960 mm	1520 x 2250 x 1960 mm	1850 x 1530 x 1960 mm	2010 x 2270 x 2240 mm	2290 x 1820 x 2080 mm	2290 x 2120 x 2080 mm		



NOTE

- 1.The manufacturer reserves the right to modify the design, specifications, mechanisms, etc., To improve the performances of the machine without notice.
All the specifications show below are just for reference.
- 2.Items marked ● are for 2A.3A.ASD II , TDNC types only.
- 3.Items marked ■ are for 3A.ASD II , TDNC types only.

Please visit our website for detail specifications:

ESG-2448TDNC / ESG-2460TDNC
 ESG-2480TDNC / ESG-24120TDNC
 ESG-3260TDNC / ESG-3280TDNC / ESG-32120TDNC
 Double Column Grinders

ESG-2A1224	ESG-3A1224 ESG-1224ASD II	ESG-3A1228 ESG-1228ASD II	ESG-3A1236 ESG-1236ASD II	ESG-3A1632 ESG-1632ASD II	ESG-3A1640 ESG-1640ASD II	ESG-2040ASD II
300x600mm		305x712mm	305x915mm	406x813mm	406x1020mm	506x1020mm
600mm		712mm	915mm	813mm	1020mm	1020mm
300mm		330mm		410mm		500mm
310KGS		346KGS	379KGS	420KGS	428KGS	465KGS
580mm		Standard column: 630mm / Optional high column: 720mm				720mm
300x600mm		300x700mm	300x900mm	400x800mm	400x1000mm	500x1000mm
650mm		760mm	960mm	890mm	1060mm	1060mm
730mm		830mm	1000mm	930mm	1100mm	1100mm
60HZ, 5-25m/min ; 50HZ, 5-20m/min						
0.5 -19mm		0.5 -25mm				
20-320mm/min						
310mm		350mm		430mm		510mm
340mm		380mm		460mm		520mm
5mm						
0.02mm						
ASD II :0.001-0.1mm						
-		0.001mm				
-		270mm/min				
-		70mm/min				
1mm ★ASD II : Min. display value: 0.001mm (no elevating handwheel)						
0.005mm ★ASD II : Min. display value: 0.001mm (no elevating handwheel)						
60HZ, 1750R.P.M. / 50HZ, 1450R.P.M.						
5.0HP		Standard: 5HP / Optional: 7 1/2HP				10HP
305mm		355mm				
31.75mm		50mm				
76.2mm		127mm				
2.0HP		3.0HP				
80W / ASD II :500W						
-	80W	1/4HP				
3265 x 2841 x 1810 mm		3608 x 3417 x 1943 mm	4270 x 3337 x 1935 mm	3290 x 3510 x 1943 mm	4580 x 3507 x 1944 mm	4768 x 4075 x 2075 mm
1950KGS	1990KGS	3020KGS	3330KGS	3400KGS	4000KGS	5000KGS
2250KGS	2290KGS	3520KGS	3700KGS	4000KGS	4500KGS	5800KGS
1/8 HP						
7.5HP / ASD II : 8.0HP		Standard: 8.5HP / ASD II : 9HP ; Optional: 11HP / ASD II : 11.5HP				13.5HP / ASD II : 14HP
2290 x 2120 x 2100 mm	2450 x 2180 x 2110 mm	2670 x 2290 x 2240 mm	2780 x 2290 x 2240 mm	2930 x 2290 x 2240 mm	3120 x 2290 x 2240 mm	3500 x 2290 x 2460 mm

The manufacturer reserves the right to modify the design, specifications, mechanisms, etc., To improve the performances of the machine without notice.

NATIONAL PATENT

■ Obtained National Patents:

For Grinder:

- Longitudinal straight movement construction of surface grinder.
- Timing belt straight drive system.
- Dual motors, positioning and feeding structure.

■ More National Patents:

- Timing belt drive system for the table of surface grinders.
- Roughing and micro table speed control construction.
- New travel direction change for surface grinding.





■ Obtained US Patents:

- Surface grinding table reverse construction.
- Belt drive construction for surface grinding table.

■ Obtain German patent:

- Safety handwheel system.

■ Honored with national patents:

- Multi-formed grinder.
- Dust collect / coolant and dust unit.
- NC & CNC multiple formed molds.
- One wire of table multiple transmission.
- Motor fan cooling structure.
- Simultaneous processer.
- Vacuum wind turbine structure for dust coolant.
- Improvement to dust coolant structure.
- Rotary square structure.
- Equal speed.
- New type double column complex spindle head.
- Milling grinding complex spindle head.



*Innovation **Perfection** Technology **Value***

EQUIPTOP HITECH CORP.

NO. 88, SAN FENG E. RD., HOULI DISTRICT,
TAICHUNG CITY, TAIWAN 421016

■ TEL: +886-4-25576060

■ e-mail: equiptop@hibox.hinet.net

■ FAX: +886-4-25569677.25575866

■ <http://www.equiptop.com.tw>

